

KNX eTR 101 Room Temperature Controller

Technical specifications and installation instructions

Item n° 70650



1. Description

The **Room Temperature Controller KNX eTR 101** measures the room temperature and displays the current value. Via the bus the device can receive an external measured value and process it with own data to overall temperature value (mixed value).

The **KNX eTR 101** has got an integrated PI controller for a heating and a cooling system (one or two step). The room temperature is adjusted by means of the + and - touch buttons.

Functions:

- Measurement of **temperature. Mixed value** from own measured value and external values (proportions can be set in percentage), output of minimum and maximum values
- **Display** of the actual value or the target value/basic setpoint shift
- **2 touch buttons (+/-)** for adjustment of the room temperature
- **PI controller for heating** (one or two step) and **cooling** (one or two step) depending on temperature. Control according to separate target values or basic target temperature

Configuration is made using the KNX software ETS 5. The **product file** can be downloaded from the ETS online catalogue and the Elsner Elektronik website on www.elsner-elektronik.de in the "Service" menu.

1.0.1. Scope of delivery

- Room temperature controller with mounting
- 4 screw anchors 4 x 20 mm, 4 flat head screws 3 x 25 mm

1.1. Technical specifications

Housing	plastic material, glass
Colours	similar to RAL 9003 signal white
Mounting	on-wall (directly or with a socket Ø 60 mm, resp. cavity wall socket for hole Ø 68 mm)
Protection category	IP 20
Dimensions	housing approx. 81,5 x 81,5 (W x H, mm), mounting depth approx. 12 mm
Total weight	approx. 65 g
Ambient temperature	Operation and storage -25...+80°C
Ambient air humidity	max. 95% RH, avoid bedewing
Operating voltage	KNX bus voltage
Bus current	10 mA at 50% LED brightness, 18 mA at 100% LED brightness
Data output	KNX +/- bus terminals
BCU type	Own micro controller
PEI type	0
Group addresses	max. 254
Allocations	max. 254
Communication objects	41
Temperature measurement range	-25...+80°C
Temperature resolution	0.1°C
Temperature accuracy	± 0.6°C (Mind the notes on <i>Accuracy of the measurement</i>)

The product conforms with the provisions of EU guidelines.

1.1.1. Accuracy of the measurement

Measurement variations from permanent sources of interference (see chapter *Installation position*) can be corrected in the ETS in order to ensure the specified accuracy of the sensor (offset).

When **measuring temperature**, the self-heating of the device is compensated.

2. Installation and commissioning

2.1. Installation notes



Installation, testing, operational start-up and troubleshooting should only be performed by an electrician.



CAUTION! Live voltage!

There are unprotected live components inside the device.

- National legal regulations are to be followed.
- Ensure that all lines to be assembled are free of voltage and take precautions against accidental switching on.
- Do not use the device if it is damaged.
- Take the device or system out of service and secure it against unintentional use, if it can be assumed, that risk-free operation is no longer guaranteed.

The device is only to be used for its intended purpose. Any improper modification or failure to follow the operating instructions voids any and all warranty and guarantee claims.

After unpacking the device, check it immediately for possible mechanical damage. If it has been damaged in transport, inform the supplier immediately.

The device may only be used as a fixed-site installation; that means only when assembled and after conclusion of all installation and operational start-up tasks and only in the surroundings designated for it.

Elsner Elektronik is not liable for any changes in norms and standards which may occur after publication of these operating instructions.

2.2. Installation position

The **Room Temperature Controller KNX eTR 101** is made for wall mounting. The device can be mounted directly on plaster or on a socket (Ø 60 mm).



May be installed and operated in dry interior rooms only. Avoid condensation.

When selecting an installation location, please ensure that the measurement results are affected as little as possible by external influences. Possible sources of interference include:

- Direct sunlight
- Drafts from windows and doors
- Draft from ducts which lead from other rooms or from the outside to the junction box in which the sensor is mounted
- Warming or cooling of the building structure on which the sensor is mounted, e.g. due to sunlight, heating or cold water pipes
- Connection lines and ducts which lead from warmer or colder areas to the sensor

Measurement variations from permanent sources of interference can be corrected in the ETS in order to ensure the specified accuracy of the sensor (offset).

2.3. Composition of the device

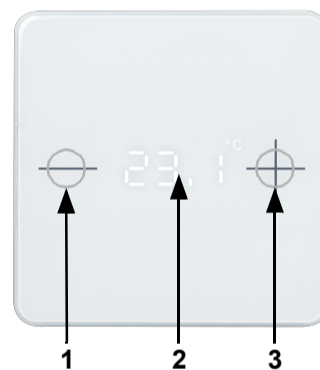

Fig. 1
Front view
1 Touch area -
2 Temperatur display
3 Touch area +

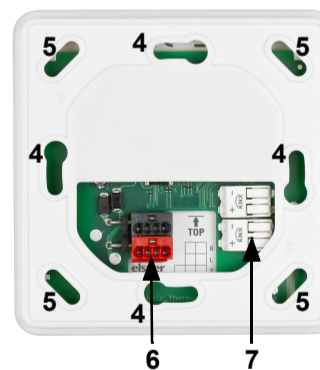

Fig. 2
Back view with mounting
4/5 Screw holes for different sockets. Fastening with 2 screws is sufficient. For wall mounting, use a fixing material suitable for the ground!
6 KNX bus terminal +/- for connection when mounted on a socket
7 Spring-loaded terminals KNX bus for mounting directly on the wall

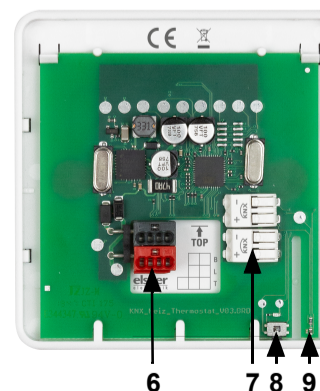

Fig. 3
Back view without mounting
6 KNX bus terminal +/- for connection when mounted on a socket
7 Spring-loaded terminals KNX bus for mounting directly on the wall
8 Programming button (recessed) for teaching device
9 Programming LED (recessed)
PRG key and LED are accessible from below/outside when the device is mounted (see chapter *Addressing the device*).

2.4. Mounting

Prepare the device

Remove the front panel from the mounting. Release the lock by moving the front panel a few millimetres upwards. The two parts can then be easily separated (Fig. 4).

Fig. 4 Locking of front panel and mounting



Screw the mounting onto the wall or socket. The connecting wires (bus line +/-) are led through the opening in the mounting.

Installation directly on the wall

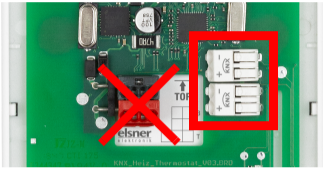

Remove the red-black KNX bus terminal, it is not required.

Connect the bus +/- connecting wires to the spring-loaded terminals on the front panel.

The wires are pushed into the connection openings.

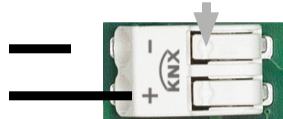
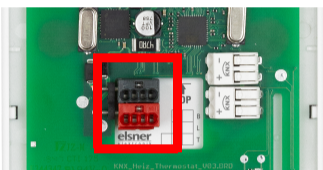

Fig. 5 Spring-loaded terminals

To pull it out, press the spring down, e.g. with a screwdriver.

Installation on a socket



If there is a cavity behind the device, e.g. when using a socket, you can use the red/black KNX bus terminal for connection.

To avoid falsifying the temperature value, use a wind-proof socket and also seal the inlet pipes against draughts.

Finish mounting

Snap the front panel into place on the mounting (see Fig. 4): Place it slightly above the centre position, hook it in and slide it downwards.

2.5. Notes on mounting and commissioning

Never expose the device to water (e.g. rain) or dust. This can damage the electronics. You must not exceed a relative humidity of 95%. Avoid condensation.

After the bus voltage has been applied, the device will enter an initialisation phase lasting a few seconds. During this phase no information can be received or sent via the bus.

3. Addressing the device

The device is delivered ex works with the bus address 15.15.255. You program a different address in the ETS by overwriting the address 15.15.255 or teach the device using the programming button.

The programming button is located at the bottom outer side of the front panel of the device and is recessed. Use a thin object to reach the button, e. g. a 1.5 mm² wire.



Fig. 6
View from bottom

4. Display and operation at the device

4.1. Adjust room temperature

Depending on the setting of the "Display mode" parameter in the device application, the **Room Temperature Controller KNX eTR 101** displays the current room temperature value (or mixed value), the target value or the shift in relation to the basic setpoint. The display can be dimmed and switched off via the bus so that no value is displayed.

Option A: Display of actual temperature (room temperature)

The current room temperature is displayed. It is *not* possible to change the room temperature manually using the +/- buttons.

Option B: Display of target temperature or basic setpoint shift

Depending on the setting, the current target value or the shift relative to the base setpoint is displayed. The temperature can be changed by touching the +/- buttons.

Target value display (absolute value):

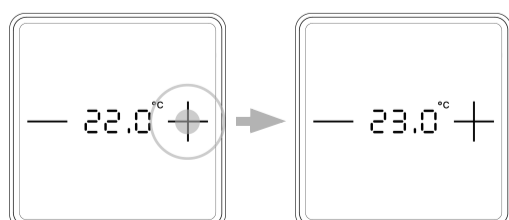

Tap +:
Increase room temperature
(target temperature is increased)

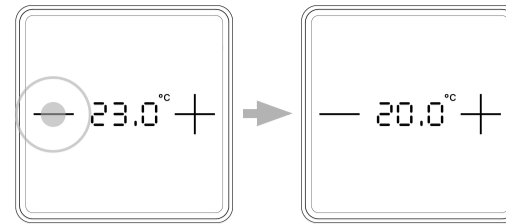

Tap -:
Lower room temperature
(target temperature is lowered)

Display of the **basic setpoint shift** (change compared to the basic setpoint of the control):

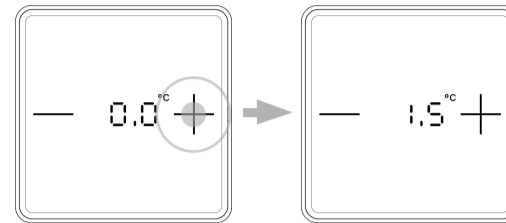

Tap +:
Increase room temperature
(Basic setpoint shift direction PLUS)

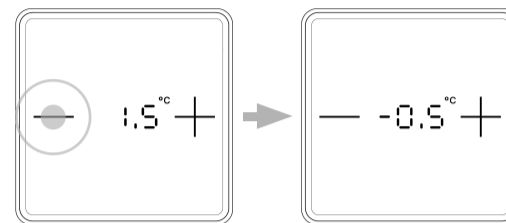

Tap -:
Lower room temperature
(Basic setpoint shift direction MINUS)

Option C: Display of actual temperature and target temperature/basic setpoint shift

During normal operation, the current room temperature is displayed. By touching the buttons, the display jumps to the target temperature or to the basic setpoint shift, depending on the presetting. Changes with + or - are visible. The display returns to the room temperature if no button is touched for 7 seconds.

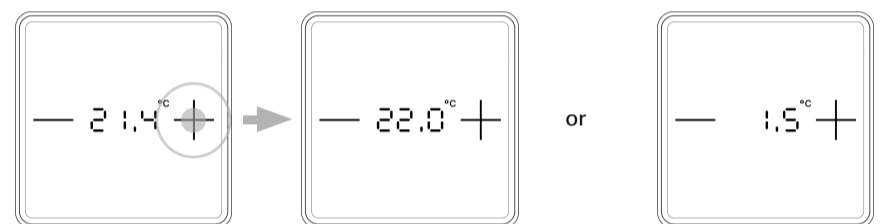

Touch the **+** or **-** button briefly: The current **target temperature** (or the basic setpoint shift) is displayed.

Tap +: Increase room temperature
(target temperature/basic setpoint shift is increased).

Tap -: Lower room temperature
(target temperature/basic setpoint shift is lowered).

General:

The step size for the change and the possible setting range are defined in the device application (ETS). There you can also define whether the manually changed values are retained after a mode change (e.g. Eco mode overnight) or reset to the stored values.

The button functions can be disabled in the ETS or locked due to operating mode with priority 1.

5. Maintenance and care

Fingerprints on the glass panel are best removed with a cloth moistened with water or a microfiber cloth. Do not use an abrasive cleaning agent or aggressive cleansing agents.